

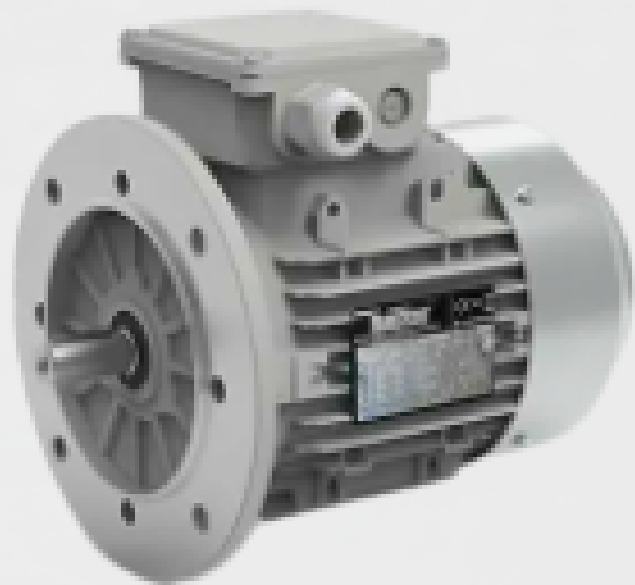

MOTORES ELÉCTRICOS

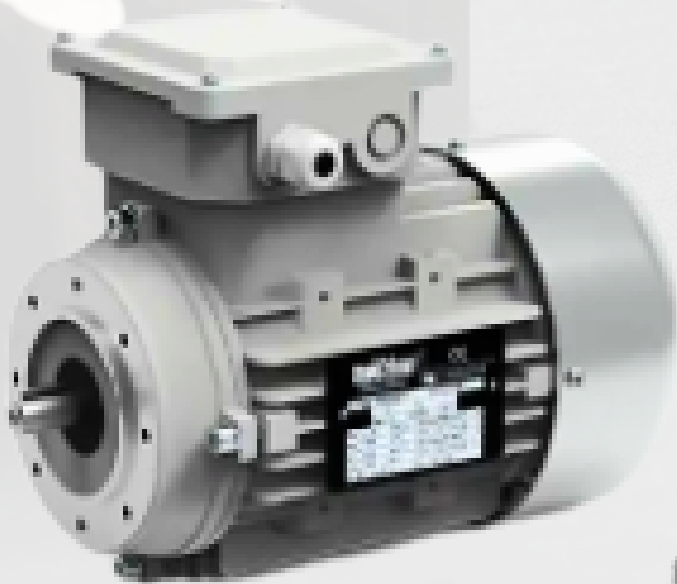

SERIE BAS RM

1 GENERAL

1.1 NORMATIVA APLICABLE

Todos los motores reúnen los requisitos exigidos en las normas y prescripciones siguientes

IEC 60 034-1	Máquinas Eléctricas Rotativas-Parte1: Valores nominales y resultados
IEC 64 034-2-1:2007	Métodos para la determinación de pérdidas y eficiencias en MER
IEC 60 034-5	Grados de protección por diseño - Código IP
IEC 60 034-6	Sistemas de refrigeración – Código IC
IEC 60 034-7	Clasificación de los tipos constructivos, formas de montaje – Código IM
IEC 60 034-8	Marcado de terminales y sentido de giro
IEC 60 034-9	Límites sonoros
IEC 60 034-11	Protección térmica
IEC 60 034-12	Características del arranque de motores monofásicos y trifásicos
IEC 60 034-14	Límites de vibraciones
IEC60 034-15	Niveles de tensión soportados por las máquinas rotativas de corriente alterna de jaula con bobinas en el estator
IEC60 034-17	Motores de inducción de jaula cuando se alimentan con convertidores
IEC60 034-28	Método de ensayo para determinar las magnitudes de los esquemas del circuito equivalente para motores de inducción de jaula trifásicos de baja tensión
IEC 60 034-30	Grados de eficiencia energética – Código IE
IEC 60 038	Tensiones normalizadas
IEC 60 072	Tamaños y datos nominales.

1.2 CONDICIONES AMBIENTALES DE LA INSTALACIÓN

La potencia de salida es la indicada para **servicio S1** según IEC 64 034-1, alimentado el motor a su tensión nominal y a la frecuencia de 50 Hz; **temperatura ambiente entre -20°C y +40°C** y altitud de instalación de hasta **1000 metros sobre el nivel del mar**.

En caso de desviación de las condiciones especificadas, la potencia de salida deberá ser modificada de acuerdo con la tabla 1.

TABLA 1

Temperatura	°C	30	35	40	45	50	55	60
Pot. Salida	%	107	104	100	95	90	83	76

Altitud	Mts.	1000	1500	2000	2500	3000	3500	4000
Pot.Salida	%	100	98	95	91	87	83	78

1.3 AISLAMIENTO Y CALENTAMIENTO

El aislamiento de los motores corresponde a la clase térmica F, según IEC 60034-1.

En su ejecución básica, y para temperatura ambiente de 40°C, los motores se han diseñado para su funcionamiento según clase térmica B, que permite un calentamiento de hasta 80K.

Calentamiento (ΔT°) y temperatura máximas en los puntos más calientes del devanado ($T_{m\acute{a}x}$) según las clases térmicas de la norma IEC 60034-1:

	ΔT°	$T_{m\acute{a}x}$
Clase B	80 °C	125 °C
Clase F	105 °C	155 °C
Clase H	125 °C	180 °C

Los motores de altura de eje 160 y superiores incorporan de serie sonda de protección térmica tipo PTC de 130°C de temperatura de corte.

2 CONSTRUCCIÓN

2.1 POSICIONES DE MONTAJE, según norma IEC34-7

B3					
B3	B6	B7	B8	V5	V6
80-355	80-160				
B5			B35		
B5	V1	V3	B35	V15	V36
80-280	80-355	80-160	80-355	80-160	
B14					
B14	B34	V18	V58	V19	V69
80-132					

2.2 MEDIDAS DE CAJAS DE BORNES

Tipo	Tamaño Carcasa	Intensidad Máxima	Tamaño Orificios
1	H56-80	2,6	2*M20*1,5
2	H90-100	6,8	2*M25*1,5
3	H112-132	15,4	2*M32*1,5
4	H160-H180	42,5	2*M40*1,5+1*M16*1.5
5	H200-225	84,2	2*M50*1,5+1*M16*1.5
6	H250-280	166,6	2*M63*1,51*M16*1.5
7	H315	358	2*M63*1,51*M16*1.5
8	H355	546	2*M63*1,51*M16*1.5

2.3 PINTURA

La pintura de cubrición es válida para grupo climático MODERATE según IEC 721-2-1, es decir, instalaciones en interiores y exteriores. Durante corto tiempo: hasta 100% de humedad relativa del aire a temperaturas de hasta +30°C. Continuo: hasta 85% de humedad relativa del aire a temperaturas de 25°C

2.4 RODAMIENTOS

Carcasa	Nº Polos	Lado Acc.	Lado Opuesto Acc.
56	2-4	6201-2RZ	6201-2RZ
63	2-4	6201-2RZ	6201-2RZ
71	2-6	6202-2RZ	6202-2RZ
80	2-8	6204-2RZ	6204-2RZ
90	2-8	6205-2RZ	6205-2RZ
100	2-8	6206-2RZ	6206-2RZ
112	2-8	6306-2RZ	6306-2RZ
132	2-8	6308-2RZ	6308-2RZ
160	2-8	6309-2RZC3	6309-2RZC3
180	2-8	6311-C3	6311-C3
200	2-8	6312-C3	6312-C3
225	2-8	6313-C3	6313-C3
250	2-6	6314-C3	6314-C3
280	2	6314-C3	6314-C3
	4-8	6317-C3	6317-C3
315	2	6317-C3	6317-C3
	4-8	NU319-C3	6319-C3
355	2	6319-C3	6319-C3
	4-8	NU322-C3	NU322-C3

Los motores MEB de altura de eje 180 y superiores llevan engrasadores de serie

3 EJECUCIÓN ELÉCTRICA

3.1 REQUISITOS DE TENSIÓN Y FRECUENCIA DE RED

La norma IEC 60034-1 define dos rangos de tolerancia de tensión y de frecuencia: Zonas A y B

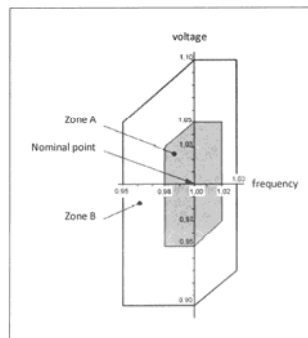

ZONA A: El motor ha de aportar el par nominal de forma continua. La respuesta del motor puede desviarse de los valores nominales y la temperatura superar a la nominal.

ZONA B: La norma IEC 60034-1 desaconseja explícitamente el funcionamiento continuo. El motor dará el par nominal de forma continua, pero los valores nominales y la temperatura pueden superar ampliamente a los valores nominales; la temperatura subirá más que en la zona A.

FORMA DE ONDA Y DESEQUILIBRIO DE FASES: están limitados por la norma IEC 60034-1 sección 7.2.11. (Factor de distorsión HVF < 3% y componente secuencia negativa < 1%).

3.2 TENSIÓN ASIGNADA

Para la tensión asignada de los motores se admite una tolerancia de $\pm 5\%$. Para las tensiones de red se prescribe una tolerancia del $\pm 10\%$.

3.3 FRECUENCIA ASIGNADA

Los motores bobinados para 50 Hz pueden ser, por regla general, conectados a redes de 60 Hz, si la tensión de red aumenta proporcionalmente con la frecuencia. Los valores relativos para el par de arranque y el par máximo quedan prácticamente sin variación, aumentándose ligeramente la intensidad de arranque. La velocidad aumenta un 20% y la potencia asignada en un 15%.

Si un motor diseñado para 50 Hz se conecta a una red de 60 Hz sin aumentar la tensión, no es posible aumentar la potencia asignada, la velocidad aumentará un 20%. Los valores de par de arranque y par máximo se reducen al 82% y la intensidad de arranque al 90%.

3.4 INTENSIDAD ASIGNADA

Las intensidades asignadas dadas en las tablas de datos son para una tensión de 400 V. La conversión a otras tensiones, manteniendo la misma potencia y frecuencia se calcula según sigue:

Tensión asignada	230 V	380 V	400 V	440 V	500 V	660 V	690 V
Factor de conversión *In	1,74	1,05	1,0	0,91	0,80	0,61	0,58

3.5 VALORES TÍPICOS DEL MOTOR Y TOLERANCIAS

Los valores típicos de rendimiento y factor de potencia dados, se refieren al motor funcionando con su carga nominal y alimentado de una red de 400 V, 50 Hz. Dichos valores varían con la carga, según se muestra en los cuadros adjuntos.

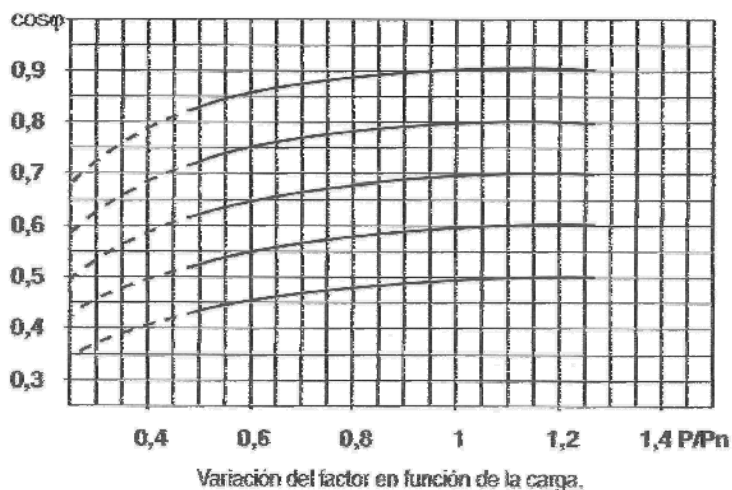
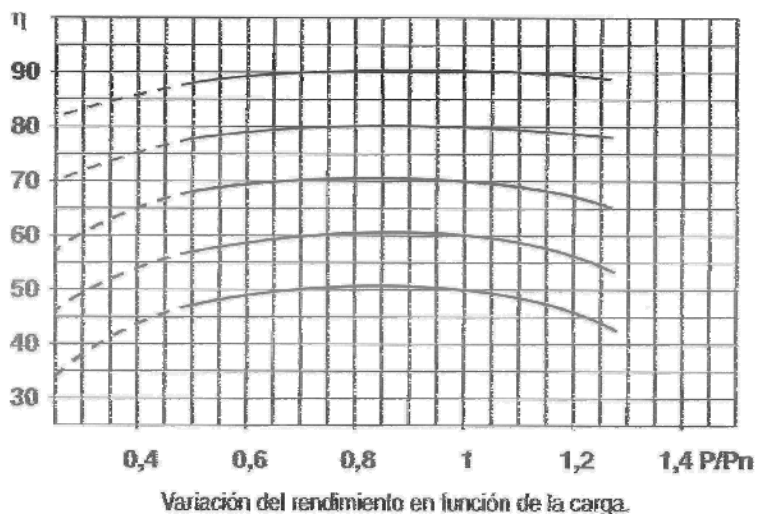

Los datos técnicos mostrados en las tablas se obtienen de ensayos. Los protocolos de pruebas pueden ser suministrados bajo demanda, y los valores obtenidos se ajustan a las tolerancias abajo indicadas, según IEC 34-1.

Valores para	Tolerancia
Rendimiento (Determinación indirecta)	-0,15(1-η) con P _N <50 kW -0,1(1-η) con P _N >50 kW
Factor de potencia	-(1-cosφ)/6 , mínimo 0,02 , máximo 0,07
Deslizamiento (con carga nominal a regimen)	±20% del teórico, para P _N > 1 kW ±30% del teórico, para P _N < 1 kW
Intensidad de arranque	+20% de la intensidad de arranque, sin límite inferior
Par de arranque	-15%, +25% del par de arranque garantizado
Par mínimo	-15% del valor garantizado
Par máximo	-10% del valor garantizado
Momento de inercia	±10% del valor garantizado

La corriente nominal, I_n, es la corriente absorbida por el motor alimentado a 400 V, 50 Hz, y se calcula mediante la formula:

$$I_n = K_w * 1000 / (\sqrt{3} * V * \cos\phi * \eta)$$

El par nominal, en Nm, se calcula mediante la formula:

$$M_n = K_w * 1000 / \omega$$

Siendo ω la velocidad angular;

$$\omega = v(\text{rpm}) * 2\pi / 60$$

El par puede ser obtenido mediante datos técnicos, siguiendo aproximadamente la curva del diagrama.

3.6 CAPACIDAD DE SOBRECARGA

Los motores trifásicos pueden, en regimen de calentamiento, sobrecargarse durante 15 segundos con 1,5 veces el par asignado a la tensión asignada. Esta capacidad de sobrecarga según IEC 60036-1 parte 1, no origina un calentamiento perjudicial.

Utilizando la clase térmica F, los motores clase B pueden funcionar continuamente con una sobrecarga del 12%.

3.7 FRECUENCIA DE ARRANQUES

Se admite el número de arranques según la tabla siguiente, siempre y cuando se observen las siguientes condiciones:

- Momento de inercia igual o menor al momento de inercia del motor.
- Par resistente aumentado al cuadrado con el numero de revoluciones hasta el par asignado.
- Arranques en intervalos regulares.

Arranques/h admisibles con número de polos

Altura de eje	polos=2	polos=4	polos=6
56 – 71	100	250	350
80 – 100	60	140	160
112 – 132	30	60	80
160 - -180	15	30	50
200 – 225	8	15	30
250 - 315	4	8	12

3.8 FUNCIONAMIENTO DEL MOTOR CON CONVERTIDOR

La adición del convertidor de frecuencia al motor trifásico con rotor de jaula lo transforma en un accionamiento de velocidad variable cuya curva par-velocidad es la siguiente

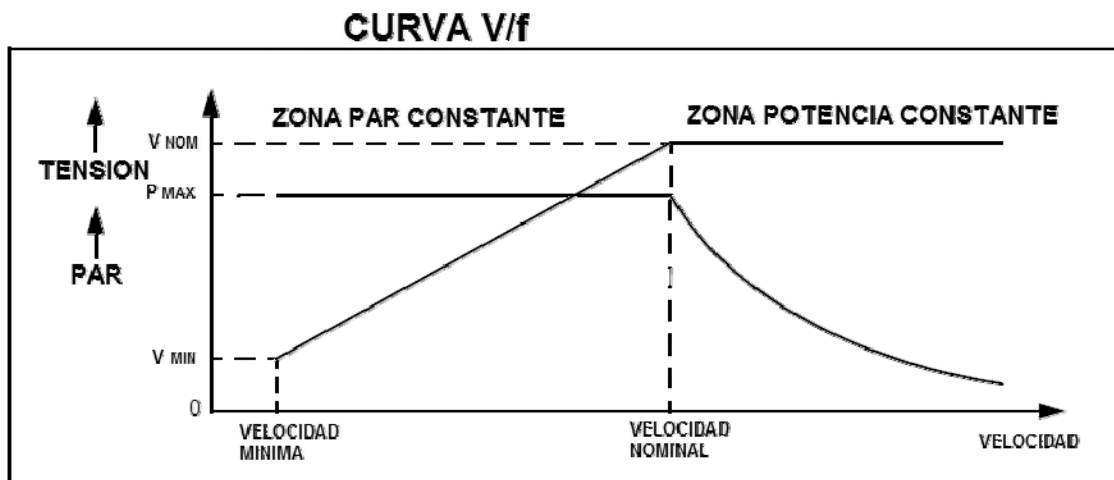

Cuando el motor funciona alimentado a través de un convertidor electrónico de frecuencia, con variación de tensión y frecuencia, se obtienen ahorros de energía y un versátil funcionamiento. (No se trata de sistemas que sólo controlen la tensión, arrancadores, que sólo pueden funcionar por cortos periodos de tiempo).

Nuestros motores son válidos para funcionar con convertidor, pero se han de observar algunas peculiaridades.

EN GENERAL:

- Se producen pérdidas adicionales, debido a que la onda de alimentación no es sinusoidal.
- Aumentan las tensiones de aislamiento en bobinados
- Aumenta el ruido acústico, porque la onda de alimentación no es sinusoidal.
- Corrientes parásitas adicionales en rodamientos. (Se recomiendan rodamientos aislados, en extremo opuesto a accionamiento, para carcasas a partir de 250).
- Contemplar posibles problemas de compatibilidad electromagnética.

DEPENDIENDO DEL RANGO DE FRECUENCIAS DE FUNCIONAMIENTO:

- A baja velocidad disminuye de forma cuadrática la autoventilación.
- A alta velocidad aumenta el nivel de ruido acústico.
- A alta velocidad disminuyen los periodos de reengrase.
- Máxima velocidad debido a disminución del par de vuelco en debilitamiento de campo.
- Controlar máxima velocidad de giro.

3.9 EFICIENCIA

En junio de 2011 se estableció un valor mínimo de eficiencia IE2, estipulado legalmente para los motores de inducción de baja tensión comercializados o instalados en el espacio común europeo. Desde el 1 de enero de 2015 el mínimo nivel de eficiencia en Europa pasó de IE2 a IE3 para todos los motores con potencia superior o igual a 7.5Kw alimentados por red, en 2, 4 y 6 polos.

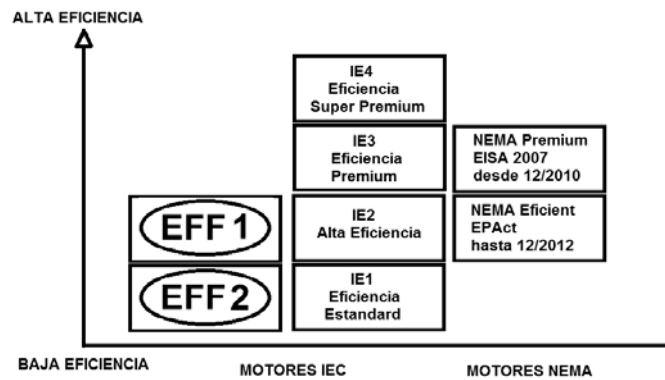
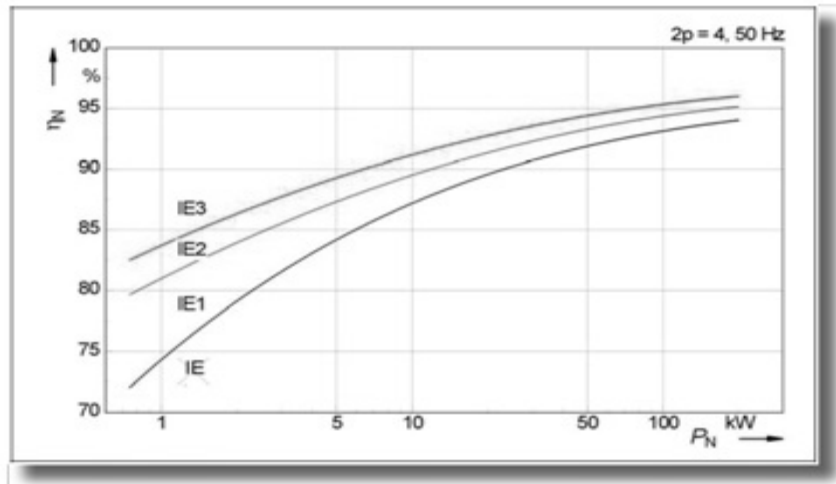

4 INFORMACIÓN TÉCNICA DE LOS MOTORES IE1

MOTORES DE 2 POLOS (3000 RPM/50Hz, 3600 RPM/60Hz) 400 V 50Hz

TIPO	POTENCIA		CORRIENTE 400V	RPM	Eff	cosφ	PAR ARR/PAR NOM	CORR ARR/COR NOM	PAR MAX/PAR NOM	NIVEL SONORO LwdB(A)	PESO
	kW	HP			%						kg
TB561-2	0.09	0.12	0.27	2700	62	0.77	2.2	2.1	5.2	57	3.8
TB562-2	0.12	0.16	0.35	2700	64	0.78	2.2	2.1	5.2	57	4
TB63M1-2	0.18	0.25	0.5	2720	65	0.8	2.3	2.3	5.5	61	4.5
TB63M2-2	0.25	0.34	0.65	2720	68	0.81	2.3	2.3	5.5	61	4.7
TB71M1-2	0.37	0.5	0.96	2755	69	0.81	2.2	2.3	6.1	64	6
TB71M2-2	0.55	0.75	1.3	2790	74	0.82	2.3	2.3	6.1	64	6.3
TB80M1-2	0.75	1	1.79	2845	75	0.83	2.3	2.2	6.1	67	10
TB80M2-2	1.1	1.5	2.44	2835	76.2	0.84	2.3	2.2	6.9	67	11
TB90S-2	1.5	2	3.29	2850	78.5	0.84	2.3	2.2	7.0	72	13
TB90L-2	2.2	3	4.6	2855	81	0.85	2.3	2.2	7.0	72	14
TB100L-2	3	4	6.02	2860	82.6	0.87	2.3	2.2	7.5	76	24
TB112M-2	4	5.5	7.8	2880	84.2	0.88	2.3	2.2	7.5	77	28
TB132S1-2	5.5	7.5	10.5	2900	85.7	0.88	2.3	2.2	7.5	80	40
TB132S2-2	7.5	10	14.15	2900	87	0.88	2.3	2.2	7.5	80	43
TG-160M1-2	11	15	20.2	2930	88.4	0.89	2.2	7.5	2.3	86	107
TG-160M2-2	15	20	27.2	2930	89.4	0.89	2.2	7.5	2.3	86	114
TG-160L-2	18.5	25	33.5	2930	90	0.9	2.2	7.5	2.3	86	133
TG-180M-2	22	30	39.7	2940	90.5	0.9	2	7.5	2.3	89	165
TG-200L1-2	30	40	53.2	2950	91.4	0.9	2	7.5	2.3	92	218
TG-200L2-2	37	50	65.5	2950	92	0.9	2	7.5	2.3	92	230
TG-225M-2	45	60	79.1	2960	92.5	0.9	2	7.5	2.3	92	290
TG-250M-2	55	75	96	2970	93	0.9	2	7.5	2.3	93	359
TG-280S-2	75	100	130	2975	93.6	0.9	2	7	2.3	94	475
TG-280M-2	90	125	155	2975	93.9	0.91	2	7.1	2.3	94	510
TG-315S-2	110	150	187	2975	94	0.91	1.8	7.1	2.2	96	875
TG-315M-2	132	180	224	2975	94.5	0.91	1.8	7.1	2.2	96	963
TG-315L1-2	160	220	268	2975	94.6	0.92	1.8	7.1	2.2	99	1010
TG-315L2-2	200	270	334	2975	94.8	0.92	1.8	7.1	2.2	99	1138
TG-355M-2	250	340	418	2980	94.8	0.92	1.6	7.1	2.2	103	1900
TG-355L-2	315	430	526	2980	94.8	0.92	1.6	7.1	2.2	103	2300

MOTORES DE 4 POLOS (1500 RPM/50Hz, 1800 RPM/60Hz) 400 V 50Hz

TIPO	POTENCIA		CORRIENTE 400V	RPM	Eff	cosφ	PAR ARR/PAR NOM	CORR ARR/COR NOM	PAR MAX/PAR NOM	NIVEL SONORO LwdB(A)	PESO
	KW	HP			%						kg
TB561-4	0.06	0.08	0.22	1300	56	0.7	2.1	2.0	4.0	48	3.8
TB562-4	0.09	0.12	0.31	1300	58	0.72	2.1	2.0	4.0	48	4
TB63M1-4	0.12	0.18	0.42	1310	57	0.72	2.2	2.1	4.4	52	4.5
TB63M2-4	0.18	0.25	0.59	1310	60	0.73	2.2	2.1	4.4	52	4.7
TB71M1-4	0.25	0.34	0.75	1340	65	0.74	2.2	2.1	5.2	55	6
TB71M2-4	0.37	0.5	1.1	1340	67	0.75	2.2	2.1	5.2	55	6.3
TB80M1-4	0.55	0.75	1.44	1390	71	0.75	2.3	2.4	5.2	58	10
TB80M2-4	0.75	1	1.85	1390	73	0.76	2.3	2.3	6.0	58	11
TB90S-4	1.1	1.5	2.7	1390	76.2	0.77	2.3	2.3	6.0	61	12
TB90L-4	1.5	2	3.53	1400	78.5	0.78	2.3	2.3	6.0	61	14
TB100L1-4	2.2	3	4.83	1420	81	0.81	2.3	2.3	7.0	64	23
TB100L2-4	3	4	6.4	1420	82.6	0.82	2.3	2.3	7.0	64	25
TB112M-4	4	5.5	8.36	1435	84.2	0.82	2.3	2.3	7.0	65	29
TB132S-4	5.5	7.5	11.12	1440	85.7	0.83	2.3	2.3	7.0	71	43
TB132M-4	7.5	10	14.8	1450	87	0.84	2.3	2.3	7.0	71	55
TG-160M-4	11	15	21.4	1460	88.4	0.84	2.2	7	2.3	75	110
TG-160L-4	15	20	28.5	1460	89.4	0.85	2.2	7.5	2.3	75	129
TG-180M-4	18.5	25	34.5	1470	90	0.86	2.2	7.5	2.3	76	160
TG-180L-4	22	30	41.2	1470	90.5	0.86	2.2	7.5	2.3	76	178
TG-200L-4	30	40	55.5	1470	91.4	0.86	2.2	7.2	2.3	79	228
TG-225S-4	37	50	67.5	1475	92	0.87	2.2	7.2	2.3	81	288
TG-225M-4	45	60	81.1	1475	92.5	0.87	2.2	7.2	2.3	81	313
TG-250M-4	55	75	99	1480	93	0.87	2.2	7.2	2.3	83	376
TG-280S-4	75	100	132	1480	93.6	0.88	2.2	6.8	2.3	86	508
TG-280M-4	90	125	157	1480	93.9	0.88	2.2	6.8	2.3	86	581
TG-315S-4	110	150	191	1480	94.2	0.88	2.1	6.9	2.2	93	846
TG-315M-4	132	180	231	1480	94.2	0.88	2.1	6.9	2.2	93	940
TG-315L1-4	160	220	275	1480	94.2	0.89	2.1	6.9	2.2	97	1044
TG-315L2-4	200	270	342	1480	94.4	0.89	2.1	6.9	2.2	97	1162
TG-355M-4	250	340	426	1490	94.4	0.9	2.1	6.9	2.2	101	1700
TG-355L-4	315	430	537	1490	94.4	0.9	2.1	6.9	2.2	101	1900

MOTORES DE 6 POLOS (1000 RPM/50Hz, 1200 RPM/60Hz) 400 V 50Hz

TIPO	POTENCIA		CORRIENTE 400V	RPM	Eff	cosφ	PAR ARR/PAR NOM	CORR ARR/COR NOM	PAR MAX/PAR NOM	NIVEL SONORO LwdB(A)	PESO
	KW	HP			%						kg
TB71M1-6	0.18	0.25	0.7	870	56	0.66	2.0	1.9	4.0	52	6
TB71M2-6	0.25	0.34	0.9	870	59	0.68	2.0	1.9	4.0	52	6.3
TB80M1-6	0.37	0.5	1.17	880	62	0.7	2.0	1.9	4.7	54	10
TB80M2-6	0.55	0.75	1.6	880	65	0.72	2.1	1.9	4.7	54	11
TB90S-6	0.75	1	2.18	905	69	0.72	2.1	2.0	5.3	57	13
TB90L-6	1.1	1.5	3.02	905	72	0.73	2.1	2.0	5.5	57	14
TB100L-6	1.5	2	3.8	920	76	0.76	2.1	2.0	5.5	61	23
TB112M-6	2.2	3	5.5	935	79	0.76	2.1	2.0	6.5	65	28
TB132S-6	3	4	7.4	960	81	0.76	2.1	2.1	6.5	69	38
TB132M1-6	4	5.5	9.3	960	82	0.76	2.1	2.1	6.5	69	50
TB132M2-6	5.5	7.5	12.6	960	84	0.77	2.1	2.1	6.5	69	57
TG-160M-6	7.5	10	16.3	970	86	0.77	2	6.5	2.1	73	106
TG-160L-6	11	15	23.3	970	87.5	0.78	2	6.5	2.1	73	122
TG-180L-6	15	20	30	970	89	0.81	2	7	2.1	73	167
TG-200L1-6	18.5	25	36.6	980	90	0.81	2.1	7	2.1	76	236
TG-200L2-6	22	30	43.1	980	90	0.83	2	7	2.1	76	247
TG-225M-6	30	40	57.6	980	91.2	0.84	2	7	2.1	76	287
TG-250M-6	37	50	69.8	980	91.7	0.86	2.1	7	2.1	78	355
TG-280S-6	45	60	82	980	92.1	0.86	2.1	7	2	80	444
TG-280M-6	55	75	100	980	92.5	0.86	2.1	7	2	80	498
TG-315S-6	75	100	136	985	93.3	0.86	2	6.7	2	85	859
TG-315M-6	90	125	163	985	93.3	0.86	2	6.7	2	85	950
TG-315L1-6	110	150	198	985	94	0.86	2	6.7	2	85	1031
TG-315L2-6	132	180	234	985	94.2	0.87	2	6.7	2	85	1107
TG-355M1-6	160	220	283	990	94.5	0.88	1.9	6.7	2	92	1550
TG-355M2-6	200	270	353	990	94.5	0.88	1.9	6.7	2	92	1600
TG-355L-6	250	340	442	990	94.5	0.88	1.9	6.7	2	92	1700

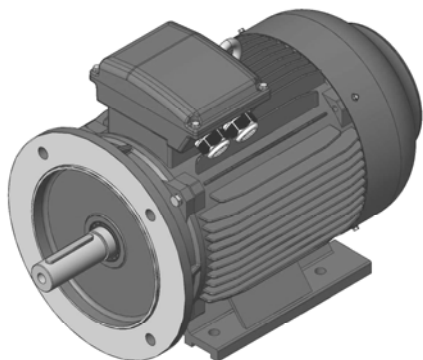

MOTORES DE 8 POLOS (750 RPM/50Hz, 900 RPM/60Hz) 400 V 50Hz

TIPO	POTENCIA		CORRIENTE 400V	RPM	Eff	cosφ	PAR ARR/PAR NOM	CORR ARR/COR NOM	PAR MAX/PAR NOM	NIVEL SONORO LwdB(A)	PESO
	KW	HP			%						kg
TB80M1-8	0.18	0.25	0.79	645	51	0.61	1.9	1.8	3.3	52	10
TB80M2-8	0.25	0.34	1.05	645	54	0.61	1.9	1.8	3.3	52	11
TB90S-8	0.37	0.5	1.4	675	62	0.61	1.9	1.8	4.0	56	13
TB90L-8	0.55	0.75	2.06	680	63	0.61	2.0	1.8	4.0	56	15
TB100L1-8	0.75	1	2.3	680	70	0.67	2.0	1.8	4.0	59	23
TB100L2-8	1.1	1.5	3.2	680	72	0.69	2.0	1.8	5.0	59	25
TB112M-8	1.5	2	4.22	690	74	0.7	2.0	1.8	5.0	61	28
TB132S-8	2.2	3	5.7	710	79	0.71	2.0	1.8	6.0	64	40
TB132M-8	3	4	7.4	710	80	0.73	2.0	1.8	6.0	64	45
TG-160M1-8	4	5.5	9.76	720	81	0.73	1.9	6	2	68	95.5
TG-160M2-8	5.5	7.5	12.9	720	83	0.74	1.9	6	2	68	107
TG-160L-8	7.5	10	16.9	720	85.5	0.75	1.9	6	2	68	128
TG-180L-8	11	15	24.2	730	87.5	0.75	2	6.5	2	70	169
TG-200L-8	15	20	32.4	730	88	0.76	2	6.6	2	73	236
TG-225S-8	18.5	25	39	730	90	0.76	1.9	6.6	2	73	274
TG-225M-8	22	30	45	730	90.5	0.78	1.9	6.6	2	73	290
TG-250M-8	30	40	60.2	735	91	0.79	1.9	6.5	2	75	370
TG-280S-8	37	50	73.9	740	91.5	0.79	1.9	6.6	2	76	488
TG-280M-8	45	60	89.4	740	92	0.79	1.9	6.6	2	76	563
TG-315S-8	55	75	106	735	92.8	0.81	1.8	6.6	2	82	852
TG-315M-8	75	100	143	735	93.5	0.81	1.8	6.2	2	82	933
TG-315L1-8	90	125	169	735	93.8	0.82	1.8	6.4	2	82	1027
TG-315L2-8	110	150	206	735	94	0.82	1.8	6.4	2	82	1117
TG-355M1-8	132	180	248	740	93.7	0.82	1.8	6.4	2	90	2000
TG-355M2-8	160	220	299	740	94.2	0.82	1.8	6.4	2	90	2150
TG-355L-8	200	270	368	740	94.5	0.83	1.8	6.4	2	90	2250

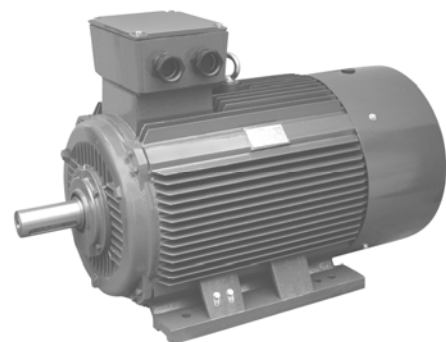

INFORMACIÓN TÉCNICA DE LOS MOTORES IE2

MOTORES DE 2 POLOS (3000 RPM/50Hz, 3600 RPM/60Hz) 400 V 50Hz

TIPO	POTENCIA		CORRIENTE 400V	RPM	Eff	cosφ	PAR ARR/PAR NOM	CORR ARR/COR NOM	PAR MAX/PAR NOM	NIVEL SONORO LwdB(A)	PESO
	kW	HP			%						kg
MA-80M1-2	0.75	1	1.7	2850	77.4	0.82	2.3	6.8	2.3	62	11,3
MA-80M2-2	1.1	1,5	2.4	2870	79.6	0.83	2.3	7.1	2.3	62	12,5
MA-90S-2	1.5	2	3.2	2880	81.3	0.84	2.3	7.3	2.3	67	14,7
MA-90L-2	2.2	3	4.5	2880	83.2	0.85	2.3	7.6	2.3	67	15,9
MA-100L1-2	3	4	5.9	2880	84.6	0.87	2.2	7.8	2.3	74	27,2
MA-112M-2	4	5,5	7.6	2900	85.8	0.88	2.3	8.1	2.3	77	31,7
MA-132S1-2	5.5	7,5	10.4	2910	87	0.88	2.2	8.2	2.3	79	45,2
MA-132S2-2	7.5	10	13.8	2910	88.1	0.89	2.2	7.8	2.3	79	48,6
MG-160M1-2	11	15	20	2940	89.4	0.89	2.2	7.9	2.3	81	121
MG-160M2-2	15	20	26.9	2940	90.3	0.89	2.2	8	2.3	81	128,9
MG-160L-2	18.5	25	33	2940	90.9	0.89	2.2	8	2.3	81	150,3
MG-180M-2	22	30	39.1	2950	91.3	0.89	2.2	8.1	2.3	83	186,5
MG-200L1-2	30	40	52.9	2960	92	0.89	2	7.5	2.3	84	246,4
MG-200L2-2	37	50	64.9	2960	92.5	0.89	2	7.5	2.3	84	259,9
MG-225M-2	45	60	78.6	2960	92.9	0.89	2.2	7.5	2.3	86	327,7
MG-250M-2	55	75	94.8	2970	93.2	0.89	2.2	7.6	2.3	89	405,7
MG-280S-2	75	100	129	2975	93.8	0.89	2	6.9	2.3	91	536,8
MG-280M-2	90	125	152	2975	94.1	0.89	2	6.9	2.3	91	576,3
MG-315S-2	110	150	186	2975	94.3	0.9	2	7	2.2	92	988,8
MG-315M-2	132	180	222	2975	94.6	0.9	2	7	2.2	92	1088,2
MG-315L1-2	160	220	265	2975	94.8	0.91	2	7.1	2.2	92	1141,3
MG-315L2-2	200	270	331	2975	95.1	0.91	2	7.1	2.2	92	1286
MG-355M-2	250	340	412	2980	95.1	0.91	1.6	7.1	2.2	100	2147
MG-355L-2	315	430	518	2980	95.1	0.91	1.6	7.2	2.2	100	2599



MOTORES DE 4 POLOS (1500 RPM/50Hz, 1800 RPM/60Hz) 400 V 50Hz

TIPO	POTENCIA		CORRIENTE 400V	RPM	Eff	cosφ	PAR ARR/PAR NOM	CORR ARR/COR NOM	PAR MAX/PAR NOM	NIVEL SONORO LwdB(A)	PESO
	kW	HP			%						kg
MA-80M2-4	0.75	1	1.8	1420	79.6	0.76	2.3	6.4	2.3	56	12,5
MA-90S-4	1.1	1,5	2.6	1420	81.4	0.77	2.3	6.6	2.3	59	13,6
MA-90L-4	1.5	2	3.5	1420	82.8	0.78	2.3	6.7	2.3	59	15,9
MA-100L1-4	2.2	3	4.7	1440	84.3	0.8	2.3	7.3	2.3	64	26
MA-100L2-4	3	4	6.2	1440	85.5	0.81	2.3	7.5	2.3	64	28,3
MA-112M-4	4	5,5	8.1	1445	86.6	0.81	2.3	7.5	2.3	65	32,8
MA-132S-4	5.5	7,5	11.1	1450	87.7	0.82	2	7.5	2.3	71	48,6
MA-132M-4	7.5	10	14.7	1450	88.7	0.83	2	7.3	2.3	71	62,2
MG-160M-4	11	15	21.3	1470	89.8	0.83	2.2	7.4	2.3	73	124,3
MG-160L-4	15	20	28.4	1470	90.6	0.84	2.2	7.5	2.3	73	145,8
MG-180M-4	18.5	25	34.4	1470	91.2	0.85	2.2	7.6	2.3	76	180,8
MG-180L-4	22	30	40.8	1470	91.6	0.85	2.2	7.7	2.3	76	201,2
MG-200L-4	30	40	55.2	1470	92.3	0.85	2.2	7.1	2.3	76	257,7
MG-225S-4	37	50	67	1480	92.7	0.86	2.2	7.3	2.3	78	325,5
MG-225M-4	45	60	80.7	1480	93.1	0.86	2.2	7.3	2.3	78	353,7
MG-250M-4	55	75	98.1	1480	93.5	0.86	2.2	7.3	2.3	79	424,9
MG-280S-4	75	100	132.1	1480	94	0.87	2.2	6.8	2.3	80	574,1
MG-280M-4	90	125	157	1480	94.2	0.88	2.2	6.9	2.3	80	656,6
MG-315S-4	110	150	189	1480	94.5	0.89	2.1	6.9	2.2	88	956
MG-315M-4	132	180	226	1480	94.7	0.89	2.1	6.9	2.2	88	1062,2
MG-315L1-4	160	220	272	1480	94.9	0.9	2.2	6.9	2.2	88	1179,8
MG-315L2-4	200	270	337	1480	95.1	0.9	2.1	6.9	2.2	88	1313,1
MG-355M-4	250	340	422	1490	95.1	0.9	2.1	6.9	2.2	95	1921
MG-355L-4	315	430	531	1490	95.1	0.9	2.1	6.9	2.2	95	2147

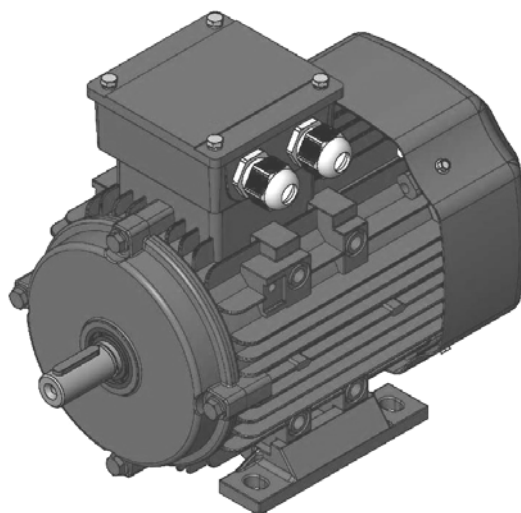

MOTORES DE 6 POLOS (1000 RPM/50Hz, 1200 RPM/60Hz) 400 V 50Hz

TIPO	POTENCIA		CORRIENTE 400V	RPM	Eff	cosφ	PAR ARR/PAR NOM	CORR ARR/COR NOM	PAR MAX/PAR NOM	NIVEL SONORO LwdB(A)	PESO
	kW	HP			%						kg
MA-90S-6	0.75	1	2	930	75.9	0.71	2	5.8	2.1	57	14,7
MA-90L-6	1.1	1,5	2.8	930	78.1	0.72	2	5.9	2.1	57	15,9
MA-100L1-6	1.5	2	3.7	930	79.8	0.72	2	5.9	2.1	61	26
MA-112M-6	2.2	3	5.4	945	81.8	0.72	2.1	6.2	2.1	65	31,7
MA-132S-6	3	4	7.1	960	83.3	0.72	2	6.4	2.1	69	43
MA-132M1-6	4	5,5	9.2	965	84.6	0.74	2	6.6	2.1	69	56,5
MA-132M2-6	5.5	7,5	12.3	965	86	0.75	2	6.8	2.1	69	64,5
MG-160M-6	7.5	10	15.9	970	87.2	0.78	2.1	6.8	2.1	73	119,8
MG-160L-6	11	15	22.7	970	88.7	0.79	2.1	6.9	2.1	73	137,9
MG-180L-6	15	20	29.8	980	89.7	0.81	2	7.3	2.1	73	188,8
MG-200L1-6	18.5	25	36.5	980	90.4	0.81	2.1	7.2	2.1	73	266,7
MG-200L2-6	22	30	42.5	980	90.9	0.81	2.1	7.3	2.1	73	279,2
MG-225M-6	30	40	56.3	980	91.7	0.82	2	6.8	2.1	74	324,4
MG-250M-6	37	50	68.5	980	92.2	0.83	2.1	7	2.1	76	401,2
MG-280S-6	45	60	81.7	980	92.7	0.85	2.1	7.2	2	78	501,8
MG-280M-6	55	75	99.5	980	93.1	0.85	2.1	7.2	2	78	562,8
MG-315S-6	75	100	135	990	93.7	0.85	2	6.5	2	83	970,7
MG-315S-6	90	125	161	990	94	0.85	2	6.6	2	83	1073,5
MG-315M-6	110	150	196	990	94.3	0.85	2	6.6	2	83	1165,1
MG-315L1-6	132	180	232	990	94.6	0.86	2	6.6	2	83	1251
MG-315L2-6	160	220	278	990	94.8	0.86	1.9	6.7	2	85	1751,5
MG-355M2-6	200	270	347	990	95.1	0.86	2	6.8	2	85	1808
MG-355L-6	250	340	434	990	95.1	0.86	2	6.8	2	85	1921



INFORMACIÓN TÉCNICA DE LOS MOTORES IE3

MOTORES DE 2 POLOS (3000 RPM/50Hz, 3600 RPM/60Hz) 400 V 50Hz

TIPO	POTENCIA		RPM	CORRIENTE	Eff	cosφ	PAR	CORR	PAR	NIVEL SONORO LwdB(A)	PESO
	KW	HP		400V	%		ARR/PAR NOM	ARR/COR NOM	MAX/PAR NOM		kg
SG-80M1-2	0.75	1	2890	1.64	80.7	0.82	2.3	7.0	2.3	62	12,6
SG-80M2-2	1.1	1,5	2890	2.31	82.7	0.83	2.2	7.3	2.3	62	13,9
SG-90S-2	1.5	2	2890	3.06	84.2	0.84	2.2	7.6	2.3	67	16,4
SG-90L-2	2.2	3	2890	4.35	85.9	0.85	2.2	7.6	2.3	67	17,7
SG-100L-2	3	4	2895	5.71	87.1	0.87	2.2	7.8	2.3	74	30,2
SG-112M-2	4	5,5	2910	7.45	88.1	0.88	2.2	8.3	2.3	77	35,2
SG-132S1-2	5.5	7,5	2940	10.1	89.2	0.88	2.0	8.3	2.3	79	50,2
SG-132S2-2	7.5	10	2940	13.7	90.1	0.88	2.0	7.9	2.3	79	54
SG-160M1-2	11	15	2950	19.6	91.2	0.89	2.0	8.1	2.3	81	134,4
SG-160M2-2	15	20	2950	26.5	91.9	0.89	2.0	8.1	2.3	81	143,1
SG-160L-2	18.5	25	2950	32.5	92.4	0.89	2.0	8.2	2.3	81	166,9
SG-180M-2	22	30	2960	38.5	92.7	0.89	2.0	8.2	2.3	83	207,1
SG-200L1-2	30	40	2970	52.1	93.3	0.89	2.0	7.6	2.3	84	273,6
SG-200L2-2	37	50	2970	64	93.7	0.89	2.0	7.6	2.3	84	288,5
SG-225M-2	45	60	2970	76.8	94.0	0.90	2.0	7.7	2.3	86	363,8
SG-250M-2	55	75	2980	93.5	94.3	0.90	2.0	7.7	2.3	89	450,4
SG-280S-2	75	100	2980	127	94.7	0.90	1.8	7.1	2.3	91	595,9
SG-280M-2	90	90	2980	151	95.0	0.90	1.8	7.1	2.3	91	639,7
SG-315S-2	110	150	2980	185	95.2	0.90	1.8	7.1	2.3	92	1097,6
SG-315M-2	132	180	2980	224	94.8	0.90	1.8	7.1	2.3	92	1208
SG-315L1-2	160	220	2980	265	95.6	0.91	1.8	7.2	2.3	92	1266,9
SG-315L2-2	200	270	2980	331	95.8	0.91	1.8	7.2	2.2	92	1427,5
SG-355M-2	250	340	2980	414	95.8	0.91	1.6	7.2	2.2	100	2383,2
SG-355L-2	315	430	2980	522	95.8	0.91	1.6	7.2	2.2	100	2884,9



MOTORES DE 4 POLOS (1500 RPM/50Hz, 1800 RPM/60Hz) 400 V 50Hz

TIPO	POTENCIA		RPM	CORRIENTE	Eff	cosφ	PAR ARR/PAR NOM	CORR ARR/COR NOM	PAR MAX/PAR NOM	NIVEL SONORO LwdB(A)	PESO
	kW	HP		400V	%						kg
SG-80M-4	0.75	1	1430	1.75	82.5	0.75	2.3	6.6	2.3	56	13,9
SG-90S-4	1.1	1,5	1440	2.48	84.1	0.76	2.3	6.8	2.3	59	15,1
SG-90L-4	1.5	2	1440	3.3	85.3	0.77	2.3	7.0	2.3	59	17,7
SG-100L1-4	2.2	3	1455	4.52	86.7	0.81	2.3	7.6	2.3	64	28,9
SG-100L2-4	3	4	1455	6.02	87.7	0.82	2.3	7.6	2.3	64	31,5
SG-112M-4	4	5,5	1460	7.95	88.6	0.82	2.2	7.8	2.3	65	36,5
SG-132S-4	5.5	7,5	1470	10.7	89.6	0.83	2.0	7.9	2.3	71	54
SG-132M-4	7.5	10	1470	14.3	90.4	0.84	2.0	7.5	2.3	71	69,1
SG-160M-4	11	15	1470	20.4	91.4	0.85	2.2	7.7	2.3	73	138
SG-160L-4	15	20	1470	27.3	92.1	0.86	2.2	7.8	2.3	73	161,9
SG-180M-4	18.5	25	1475	33.5	92.6	0.86	2.0	7.8	2.3	76	200,7
SG-180L-4	22	30	1475	39.7	93.0	0.86	2.0	7.8	2.3	76	223,4
SG-200L-4	30	40	1480	53.8	93.6	0.86	2.0	7.8	2.3	76	286,1
SG-225S-4	37	50	1485	66.1	93.9	0.86	2.0	7.4	2.3	78	361,4
SG-225M-4	45	60	1485	80.2	94.2	0.86	2.0	7.4	2.3	78	392,7
SG-250M-4	55	75	1485	97.6	94.6	0.86	2.0	7.4	2.3	79	471,7
SG-280S-4	75	100	1485	129	95.0	0.88	2.0	6.9	2.3	80	637,3
SG-280M-4	90	90	1485	155	95.2	0.88	2.0	6.9	2.3	80	728,9
SG-315S-4	110	150	1485	187	95.4	0.89	2.0	7.0	2.2	88	1061,2
SG-315M-4	132	180	1485	224	95.6	0.89	2.0	7.0	2.2	88	1179,1
SG-315L1-4	160	220	1485	270	95.8	0.89	2.0	7.1	2.2	88	1309,6
SG-315L2-4	200	270	1485	334	96.0	0.90	2.0	7.1	2.2	88	1457,6
SG-355M-4	250	340	1490	418	96.0	0.90	2.0	7.1	2.2	95	2132,4
SG-355L-4	315	430	1490	526	96.0	0.90	2.0	7.1	2.2	95	2383,5

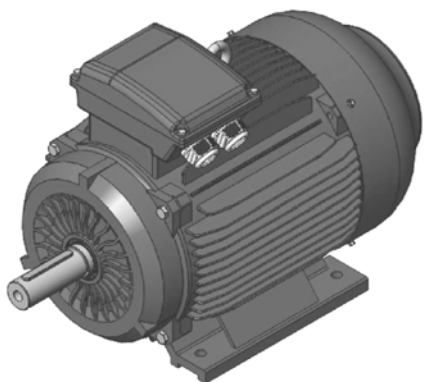

MOTORES DE 6 POLOS (1000 RPM/50Hz, 1200 RPM/60Hz) 400 V 50Hz

TIPO	POTENCIA		RPM	CORRIENTE 400V	Eff %	cos ϕ	PAR ARR/PAR NOM	CORR ARR/COR NOM	PAR MAX/PAR NOM	NIVEL SONORO LwdB(A)	PESO kg
	kW	HP									
SG-90S-6	0.75	1	955	1.93	78.9	0.71	2.0	6.0	2.1	57	16,4
SG-90L-6	1.1	1,5	955	2.69	81.0	0.73	2.0	6.0	2.1	57	17,7
SG-100L-6	1.5	2	955	3.6	82.5	0.73	2.0	6.5	2.1	61	28,9
SG-112M-6	2.2	3	970	5.09	84.3	0.74	2.0	6.6	2.1	65	35,2
SG-132S-6	3	4	970	6.84	85.6	0.74	2.0	6.8	2.1	69	47,8
SG-132M1-6	4	5,5	970	8.99	86.8	0.74	2.0	6.8	2.1	69	62,8
SG-132M2-6	5.5	7,5	970	12	88.0	0.75	2.0	7.0	2.1	69	71,6
SG-160M-6	7.5	10	980	15.4	89.1	0.79	2.0	7.0	2.1	73	133
SG-160L-6	11	15	980	22	90.3	0.80	2.0	7.2	2.1	73	153,1
SG-180L-6	15	20	980	29.3	91.2	0.81	2.0	7.3	2.1	73	209,6
SG-200L1-6	18.5	25	985	36	91.7	0.81	2.0	7.3	2.1	73	296,1
SG-200L2-6	22	30	985	42.5	92.2	0.81	2.0	7.4	2.1	73	310
SG-225M-6	30	40	985	56.2	92.9	0.83	2.0	6.9	2.1	74	360,1
SG-250M-6	37	50	990	68.1	93.3	0.84	2.0	7.1	2.1	76	445,4
SG-280S-6	45	60	990	81.6	93.7	0.85	2.0	7.3	2.0	78	557
SG-280M-6	55	75	990	98.1	94.1	0.86	2.0	7.3	2.0	78	624,8
SG-315S-6	75	100	990	133	94.6	0.84	2.0	6.6	2.0	83	1077,5
SG-315M-6	90	125	990	160	94.9	0.85	2.0	6.7	2.0	83	1191,6
SG-315L1-6	110	150	990	195	95.1	0.85	2.0	6.7	2.0	83	1293,3
SG-315L2-6	132	180	990	230	95.4	0.86	2.0	6.8	2.0	83	1388,7
SG-355M1-6	160	220	990	275	95.6	0.86	1.8	6.8	2.0	85	1944,2
SG-355M2-6	200	270	990	345	95.8	0.87	1.8	6.8	2.0	85	2006,9
SG-355L1-6	250	340	990	432	95.8	0.87	1.8	6.8	2.0	85	2132,4
SG-355L2-6	315	430	990	552	95.8	0.86	1.8	6.8	2.0	85	2354,5

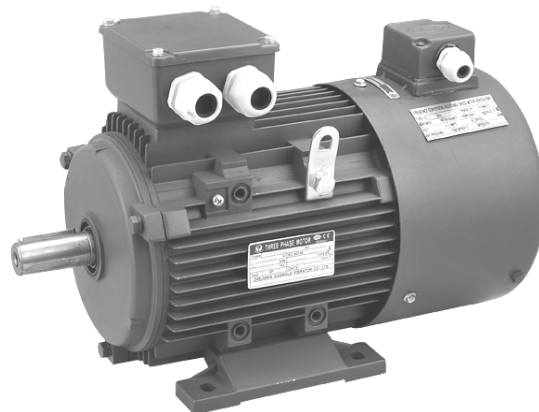

DIMENSIONES GENERALES

MONTAJE IM B3 (PATAS)

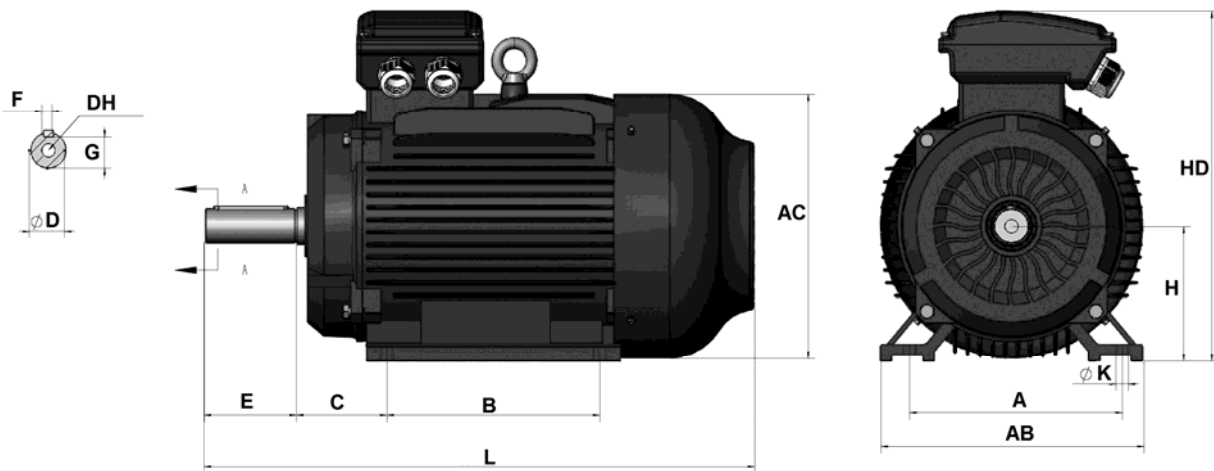

ALTURA DE EJE	POLOS	A	B	C	D	E	F	G	H	K	AB	DH	AC	IE1		IE2/IE3	
														HD	L	HD	L
56	2 4 6 8	90	71	36	9	20	3	7.2	56	5.8	115	M4x12	112	156	201		
63	2 4 6 8	100	80	40	11	23	4	8.5	63	7	135	M4x12	123	174	224		
71	2 4 6 8	112	90	45	14	30	5	11	71	7	150	M5x12	136	198	247		
80	2 4 6 8	125	100	50	19	40	6	15.5	80	10	156	M6x16	155	214	291	220	295
90S	2 4 6 8	140	100	56	24	50	8	20	90	10	175	M8x19	175	255	316	240	327
90L	2 4 6 8	140	125	56	24	50	8	20	90	10	175	M8x19	175	255	340	240	357
100L	2 4 6 8	160	140	63	28	60	8	24	100	12	204	M10x22	196	264	392	267	403
112M	2 4 6 8	190	140	70	28	60	8	24	112	12	227	M10x22	220	313	402	289	430
132S	2 4 6 8	216	140	89	38	80	10	33	132	12	258	M12x28	259	338	483	328	460
132M	2 4 6 8	216	178	89	38	80	10	33	132	12	258	M12x28	259	338	510	328	499
160M	2 4 6 8	254	210	108	42	110	12	37	160	15	314	M16x36	315	416	613	416	613
160L	2 4 6 8	254	254	108	42	110	12	37	160	15	314	M16x36	315	416	658	416	658
180M	2 4 6 8	279	241	121	48	110	14	42.5	180	15	349	M16x36	355	451	698	451	698
180L	2 4 6 8	279	279	121	48	110	14	42.5	180	15	349	M16x36	355	451	734	451	734
200L	2 4 6 8	318	305	133	55	110	16	49	200	19	388	M20x42	397	505	776	505	776
225S	4 8	356	286	149	60	140	18	53	225	19	431	M20x42	445	550	810	550	810
225M	2	356	311	149	55	110	16	49	225	19	431	M20x42	445	550	809	550	809
225M	4 6 8	356	311	149	60	140	18	53	225	19	431	M20x42	445	550	839	550	839
250M	2	406	349	168	60	140	18	53	250	24	484	M20x42	484	613	925	613	925
250M	4 6 8	406	349	168	65	140	18	58	250	24	484	M20x42	484	613	925	613	925
280S	2	457	368	190	65	140	18	58	280	24	542	M20x42	546	670	991	670	991
280S	4 6 8	457	368	190	75	140	20	67.5	280	24	542	M20x42	546	670	991	670	991
280M	2	457	419	190	65	140	18	58	280	24	542	M20x42	546	670	1046	670	1046
280M	4 6 8	457	419	190	75	140	20	67.5	280	24	542	M20x42	546	670	1046	670	1046
315S	2	508	406	216	65	140	18	58	315	28	628	M20x42	620	855	1185	855	1185
315S	4 6 8	508	406	216	80	170	22	71	315	28	628	M20x42	620	855	1220	855	1220
315M	2	508	457	216	65	140	18	58	315	28	628	M20x42	620	855	1290	855	1290
315M	4 6 8	508	457	216	80	170	22	71	315	28	628	M20x42	620	855	1325	855	1325
315L	2	508	508	216	65	140	18	58	315	28	628	M20x42	620	855	1290	855	1290
315L	4 6 8	508	508	216	80	170	22	71	315	28	628	M20x42	620	855	1325	855	1325
355M	2	610	560	254	75	140	20	67.5	355	28	726	M20x42	700	1002	1484	1002	1484
355M	4 6 8	610	560	254	95	170	25	86	355	28	726	M20x42	700	1002	1514	1002	1514
355L	2	610	630	254	75	140	20	67.5	355	28	726	M20x42	700	1002	1484	1002	1484
355L	4 6 8	610	630	254	95	170	25	86	355	28	726	M20x42	700	1002	1514	1002	1514

MONTAJE IM B5 (BRIDA B5)

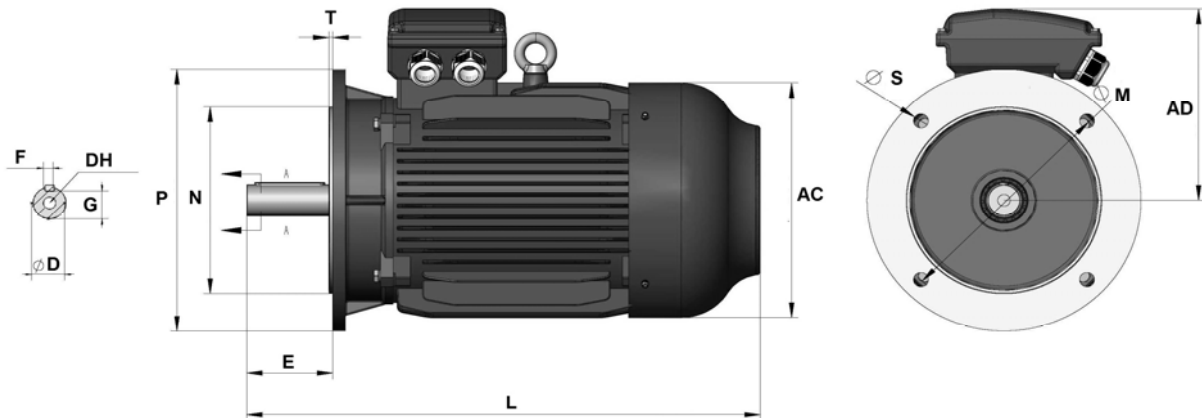

ALTURA DE EJE	POLOS	D	E	F	G	K	M	N	P	S	T	Nº AGUJ	DH	AC	IE1		IE2/IE3	
															AD	L	AD	L
56	2 4 6 8	9	20	3	7.2	5.8	100	80	120	φ7	3	4	M4x12	112	96	201		
63	2 4 6 8	11	23	4	8.5	7	115	95	140	φ10	3	4	M4x12	123	104	224		
71	2 4 6 8	14	30	5	11	7	130	110	160	φ10	3.5	4	M5x12	136	118	247		
80	2 4 6 8	19	40	6	15.5	10	165	130	200	φ12	3.5	4	M6x16	155	114	291	120	295
90S	2 4 6 8	24	50	8	20	10	165	130	200	φ12	3.5	4	M8x19	175	155	316	140	327
90L	2 4 6 8	24	50	8	20	10	165	130	200	φ12	3.5	4	M8x19	175	155	340	140	357
100L	2 4 6 8	28	60	8	24	12	215	180	250	φ15	4	4	M10x22	196	139	392	142	403
112M	2 4 6 8	28	60	8	24	12	215	180	250	φ15	4	4	M10x22	220	188	402	164	430
132S	2 4 6 8	38	80	10	33	12	265	230	300	φ15	4	4	M12x28	259	188	483	178	460
132M	2 4 6 8	38	80	10	33	12	265	230	300	φ15	4	4	M12x28	259	188	510	178	499
160M	2 4 6 8	42	110	12	37	15	300	250	350	19	5	4	M16x36	315	241	613	241	613
160L	2 4 6 8	42	110	12	37	15	300	250	350	19	5	4	M16x36	315	241	658	241	658
180M	2 4 6 8	48	110	14	42.5	15	300	250	350	19	5	4	M16x36	355	276	698	276	698
180M	2 4 6 8	48	110	14	42.5	15	300	250	350	19	5	4	M16x36	355	276	698	276	698
200L	2 4 6 8	55	110	16	49	19	350	300	400	19	5	4	M20x42	397	305	776	305	776
225S	4 8	60	140	18	53	19	400	350	450	19	5	8	M20x42	445	325	810	325	810
225M	2	55	110	16	49	19	400	350	450	19	5	8	431	445	550	809	550	809
225M	4 6 8	60	140	18	53	19	400	450	550	19	5	8	431	445	550	839	550	839
250M	2	60	140	18	53	24	500	450	550	19	5	8	M20x42	484	338	925	338	925
250M	4 6 8	65	140	18	58	24	500	450	550	19	5	8	M20x42	484	338	925	338	925
280S	2	65	140	18	58	24	500	450	550	19	5	8	M20x42	546	395	991	395	991
280S	4 6 8	75	140	20	67.5	24	500	450	550	19	5	8	M20x42	546	395	991	395	991
280M	2	65	140	18	58	24	500	450	550	19	5	8	M20x42	546	395	1046	395	1046
280M	4 6 8	75	140	20	67.5	24	500	450	550	19	5	8	M20x42	546	395	1046	395	1046
315S	2	65	140	18	58	28	600	550	660	24	6	8	M20x42	620	525	1185	525	1185
315S	4 6 8	80	170	22	71	28	600	550	660	24	6	8	M20x42	620	525	1220	525	1220
315M	2	65	140	18	58	28	600	550	660	24	6	8	M20x42	620	525	1290	525	1290
315M	4 6 8	80	170	22	71	28	600	550	660	24	6	8	M20x42	620	525	1325	525	1325
315L	2	65	140	18	58	28	600	550	660	24	6	8	M20x42	620	525	1290	525	1290
315L	4 6 8	80	170	22	71	28	600	550	660	24	6	8	M20x42	620	525	1325	525	1325
355M	2	75	140	20	67.5	28	740	680	800	24	6	8	M20x42	700	602	1484	602	1484
355M	4 6 8	95	170	25	86	28	740	680	800	24	6	8	M20x42	700	602	1514	602	1514
355L	2	75	140	20	67.5	28	740	680	800	24	6	8	M20x42	700	602	1484	602	1484
355L	4 6 8	95	170	25	86	28	740	680	800	24	6	8	M20x42	700	602	1514	602	1514

MONTAJE IM B35 (PATAS +BRIDA B5)

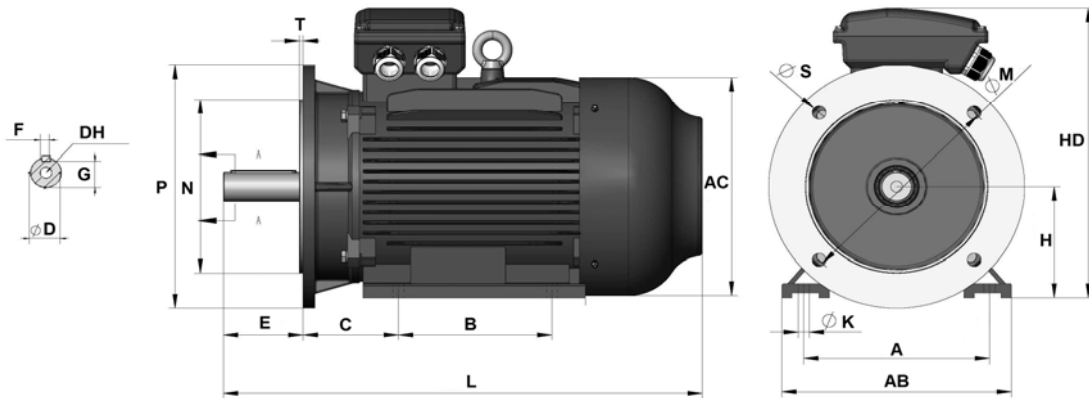

ALTURA EJE	POLOS	A	B	C	D	E	F	G	H	K	M	N	P	S	T	Nº AG	AB	AC	IE1		IE2/IE3	
																			HD	L	HD	L
56	2 4 6 8	90	71	36	9	20	3	7.2	56	5.8	100	80	120	φ7	3	4	115	112	156	201		
63	2 4 6 8	100	80	40	11	23	4	8.5	63	7	115	95	140	φ10	3	4	135	123	174	224		
71	2 4 6 8	112	90	45	14	30	5	11	71	7	130	110	160	φ10	3.5	4	150	136	198	247		
80	2 4 6 8	125	100	50	19	40	6	15.5	80	10	165	130	200	φ12	3.5	4	156	155	214	291	220	295
90S	2 4 6 8	140	100	56	24	50	8	20	90	10	165	130	200	φ12	3.5	4	175	175	255	316	240	327
90L	2 4 6 8	140	125	56	24	50	8	20	90	10	165	130	200	φ12	3.5	4	175	175	255	340	240	357
100L	2 4 6 8	160	140	63	28	60	8	24	100	12	215	180	250	φ15	4	4	204	196	264	392	267	403
112M	2 4 6 8	190	140	70	28	60	8	24	112	12	215	180	250	φ15	4	4	227	220	313	402	289	430
132S	2 4 6 8	216	140	89	38	80	10	33	132	12	265	230	300	φ15	4	4	258	259	338	483	328	460
132M	2 4 6 8	216	178	89	38	80	10	33	132	12	265	230	300	φ15	4	4	258	259	338	510	328	499
160M	2 4 6 8	254	210	108	42	110	12	37	160	15	300	250	350	19	5	4	314	315	416	613	416	613
160L	2 4 6 8	254	254	108	42	110	12	37	160	15	300	250	350	19	5	4	314	315	416	658	416	658
180M	2 4 6 8	279	241	121	48	110	14	42.5	180	15	300	250	350	19	5	4	349	355	451	698	451	698
180L	2 4 6 8	279	279	121	48	110	14	42.5	180	15	300	250	350	19	5	4	349	355	451	734	451	734
200L	2 4 6 8	318	305	133	55	110	16	49	200	19	350	300	400	19	5	4	388	397	505	776	505	776
225S	4 8	356	286	149	60	140	18	53	225	19	400	350	450	19	5	8	431	445	550	810	550	810
225M	2	356	311	149	55	110	16	49	225	19	400	350	450	19	5	8	431	445	550	809	550	809
225M	4 6 8	356	311	149	60	140	18	53	225	19	400	350	450	19	5	8	431	445	550	839	550	839
250M	2	406	349	168	60	140	18	53	250	24	500	450	550	19	5	8	484	484	613	925	613	925
250M	4 6 8	406	349	168	65	140	18	58	250	24	500	450	550	19	5	8	484	484	613	925	613	925
280S	2	457	368	190	65	140	18	58	280	24	500	450	550	19	5	8	542	546	670	991	670	991
280S	4 6 8	457	368	190	75	140	20	67.5	280	24	500	450	550	19	5	8	542	546	670	991	670	991
280M	2	457	419	190	65	140	18	58	280	24	500	450	550	19	5	8	542	546	670	1046	670	1046
280M	4 6 8	457	419	190	75	140	20	67.5	280	24	500	450	550	19	5	8	542	546	670	1046	670	1046
315S	2	508	406	216	65	140	18	58	315	28	600	550	660	24	6	8	628	620	855	1185	855	1185
315S	4 6 8	508	406	216	80	170	22	71	315	28	600	550	660	24	6	8	628	620	855	1220	855	1220
315M	2	508	457	216	65	140	18	58	315	28	600	550	660	24	6	8	628	620	855	1290	855	1290
315M	4 6 8	508	457	216	80	170	22	71	315	28	600	550	660	24	6	8	628	620	855	1325	855	1325
315L	2	508	508	216	65	140	18	58	315	28	600	550	660	24	6	8	628	620	855	1290	855	1290
315L	4 6 8	508	508	216	80	170	22	71	315	28	600	550	660	24	6	8	628	620	855	1325	855	1325
355M	2	610	560	254	75	140	20	67.5	355	28	740	680	800	24	6	8	726	700	1002	1484	1002	1484
355M	4 6 8	610	560	254	95	170	25	86	355	28	740	680	800	24	6	8	726	700	1002	1514	1002	1514
355L	2	610	630	254	75	140	20	67.5	355	28	740	680	800	24	6	8	726	700	1002	1484	1002	1484
355L	4 6 8	610	630	254	95	170	25	86	355	28	740	680	800	24	6	8	726	700	1002	1514	1002	1514

MONTAJE IM B14 (BRIDA B14)

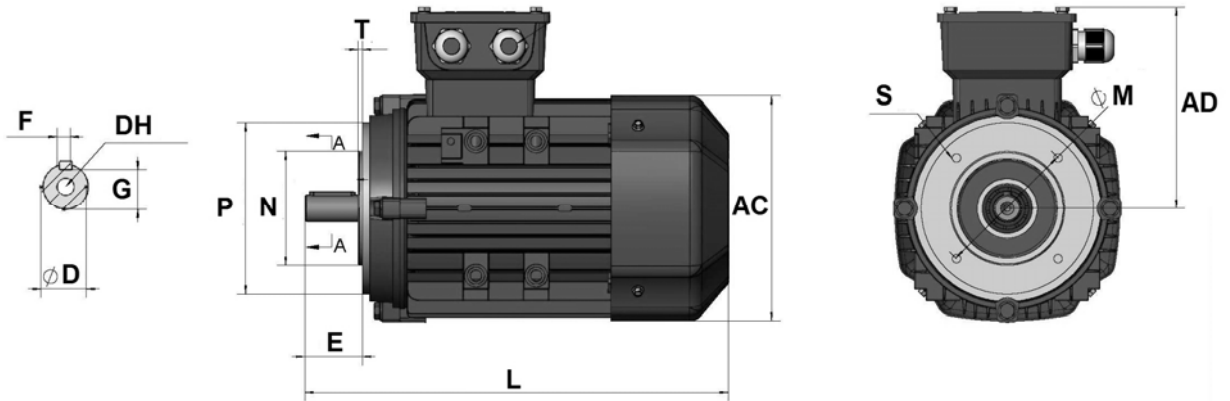

ALTURA EJE	POLOS	D	E	F	G	H	K	M	N	P	S	T	Nº AGUJ	AB	DH	AC	IE1		IE2/IE3	
																	AD	L	AD	L
56	2 4 6 8	9	20	3	7.2	56	5.8	65	50	80	M5	2,5	4	115	M4x12	112	116	201		
63	2 4 6 8	11	23	4	8.5	63	7	75	60	90	M5	2,5	4	135	M4x12	123	129	224		
71	2 4 6 8	14	30	5	11	71	7	85	70	105	M6	2,5	4	150	M5x12	136	146	247		
80	2 4 6 8	19	40	6	15.5	80	10	100	80	120	M6	3	4	156	M6x16	155	154	291	160	295
90S	2 4 6 8	24	50	8	20	90	10	115	95	140	M6	3	4	175	M8x19	175	185	316	170	327
90L	2 4 6 8	24	50	8	20	90	10	115	95	140	M6	3	4	175	M8x19	175	185	340	170	357
100L	2 4 6 8	28	60	8	24	100	12	130	110	160	M8	3,5	4	204	M10x22	196	184	392	187	403
112M	2 4 6 8	28	60	8	24	112	12	130	110	160	M8	3,5	4	227	M10x22	220	233	402	209	430
132S	2 4 6 8	38	80	10	33	132	12	165	130	200	M10	3,5	4	258	M12x28	259	238	483	228	460
132M	2 4 6 8	38	80	10	33	132	12	165	130	200	M10	3,5	4	258	M12x28	259	238	510	228	499



MONTAJE IM B34 (PATAS + BRIDA B14)

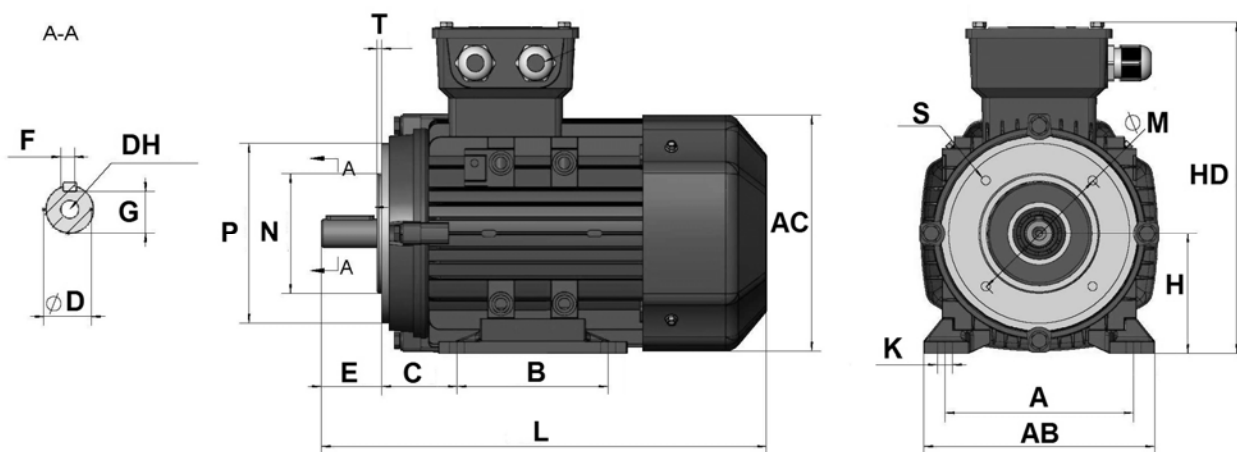

ALTURA EJE	POLOS	D	E	F	G	H	K	M	N	P	S	T	N° AGUJ	AB	DH	AC	IE1		IE2/IE3	
																	HD	L	HD	L
56	2 4 6 8	9	20	3	7.2	56	5.8	65	50	80	M5	2,5	4	115	M4x12	112	156	201		
63	2 4 6 8	11	23	4	8.5	63	7	75	60	90	M5	2,5	4	135	M4x12	123	174	224		
71	2 4 6 8	14	30	5	11	71	7	85	70	105	M6	2,5	4	150	M5x12	136	198	247		
80	2 4 6 8	19	40	6	15.5	80	10	100	80	120	M6	3	4	156	M6x16	155	214	291	220	295
90S	2 4 6 8	24	50	8	20	90	10	115	95	140	M6	3	4	175	M8x19	175	255	316	240	327
90L	2 4 6 8	24	50	8	20	90	10	115	95	140	M6	3	4	175	M8x19	175	255	340	240	357
100L	2 4 6 8	28	60	8	24	100	12	130	110	160	M8	3,5	4	204	M10x22	196	264	392	267	403
112M	2 4 6 8	28	60	8	24	112	12	130	110	160	M8	3,5	4	227	M10x22	220	313	402	289	430
132S	2 4 6 8	38	80	10	33	132	12	165	130	200	M10	3,5	4	258	M12x28	259	338	483	328	460
132M	2 4 6 8	38	80	10	33	132	12	165	130	200	M10	3,5	4	258	M12x28	259	338	510	328	499



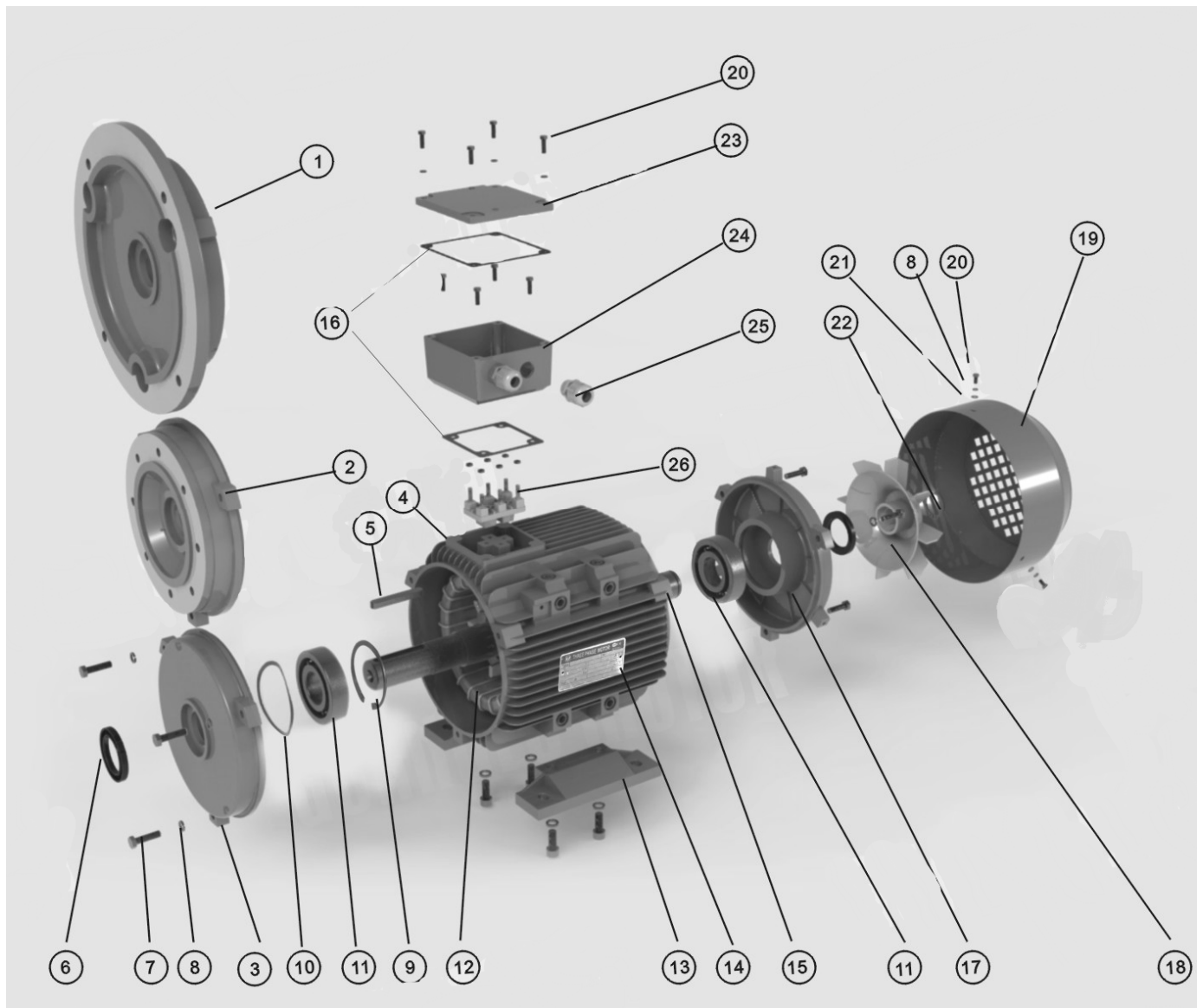

1 Brida B5	8 Arandela de fijación	15 Rotor	22 Fijación ventilador
2 Brida B14	9 Circlip	16 Junta	23 Tapa caja bornas
3 Escudo del.	10 Arandela comp..	17 Escudo trasero	24 Base caja bornas
4 Cuerpo motor	11 Rodamientos	18 Ventilador	25 Prensa-estopas
5 Chaveta	12 Estator	19 Protección vent.	26 Placa bornas
6 Junta estanqueidad	13 Pata	20 Tornillo	
7 Cáncamo	14 Placa caract.	21 Arandela	

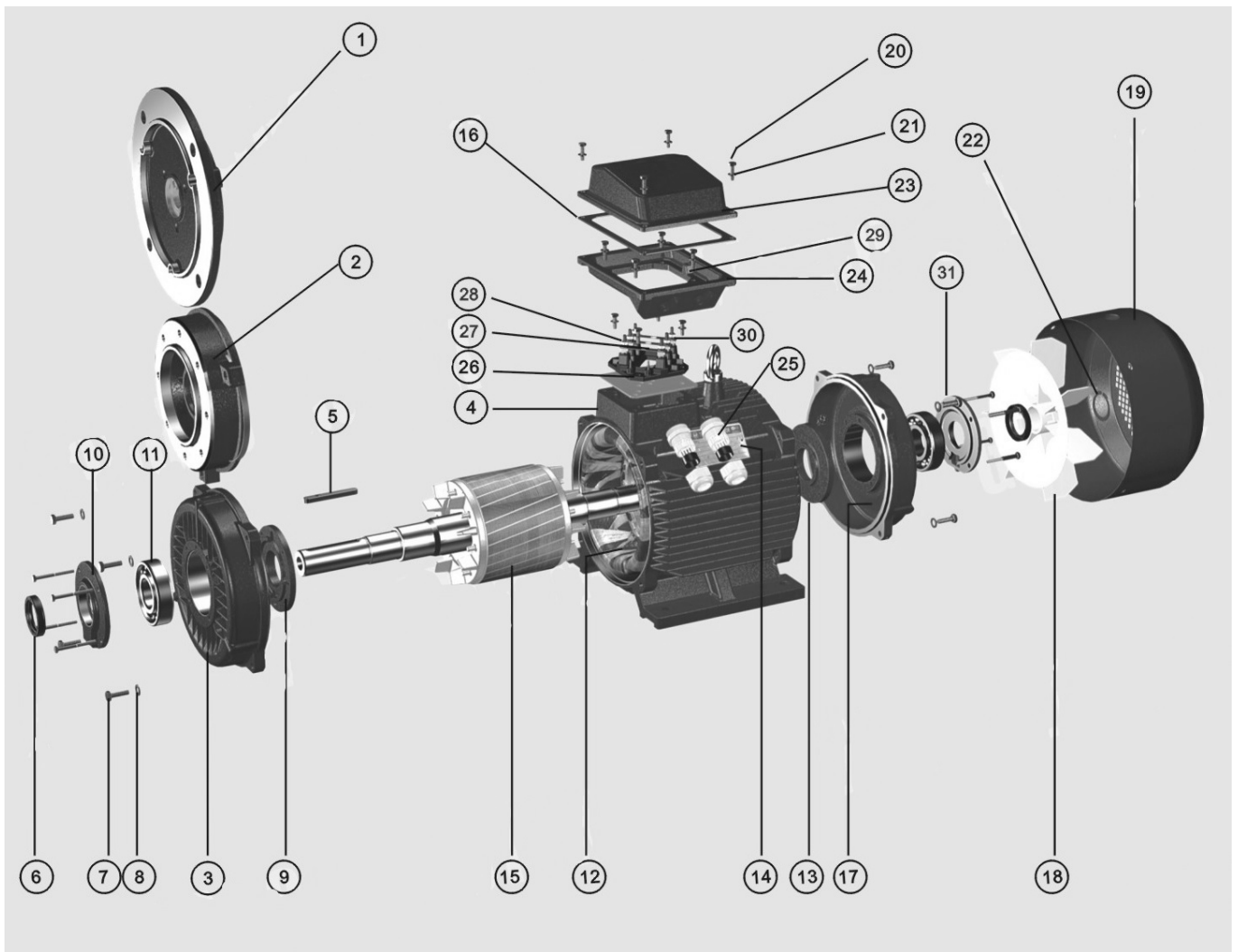

1 Brida B5	9 Tapeta rod. interna	17 Escudo trasero	25 Prensa-estopas
2 Brida B14	10 Tapeta rod. Ext.	18 Ventilador	26 Placa bornas
3 Escudo delantero	11 Rodamiento	19 Protección Vent.	27 Bloque conex.
4 Cuerpo motor	12 Estator	20 Tornillo	28 Bornas
5 Chaveta	13 Tapeta rod. Int.	21 Arandela fijación	29 Cáncamo
6 Junta estanqueidad	14 Placa caract.	22 Fijación ventilador	30 Bloque bornas
7 Tornillo	15 Rotor	23 Tapa caja bornas	31 Tapeta rod. Ext.
8 Arandela	16 Junta	24 Base placa bornas	

REDUCTORES Y MOTORREDUCTORES DE SIN FIN CORONA Serie MAX-----	CRA05 -----	<input type="checkbox"/>
REDUCTORES Y MOTORREDUCTORES COAXIALES Serie MAX -----	CRE05 -----	<input type="checkbox"/>
REDUCTORES Y MOTORREDUCTORES ORTOGONALES Serie MAX-----	GO09 -----	<input type="checkbox"/>
REDUCTORES Y MOTORREDUCTORES PARALELOS Serie MAX -----	GP09 -----	<input type="checkbox"/>
REDUCTORES Y MOTORREDUCTORES Serie ALU -----	AT15 -----	<input type="checkbox"/>
REDUCTORES Y MOTORREDUCTORES SIN FIN CORONA Serie FIT -----	AS15 -----	<input type="checkbox"/>
REDUCTORES Y MOTORREDUCTORES COAXIALES Serie INT -----	ET11 -----	<input type="checkbox"/>
REDUCTORES Y MOTORREDUCTORES COAXIALES Serie WES -----	ES15 -----	<input type="checkbox"/>
REDUCTORES Y MOTORREDUCTORES ORTOGONALES Serie COC -----	GT11 -----	<input type="checkbox"/>
MOTOVARIADORES -----	VAM11 -----	<input type="checkbox"/>
REDUCTORES Y MOTORREDUCTORES PLANETARIOS Serie PLA -----	D15 -----	<input type="checkbox"/>
MOTORES ELECTRICOS -----	TX 09 -----	<input type="checkbox"/>
MOTORES ELECTRICOS – SERIE MEB -----	RM 16 -----	<input type="checkbox"/>

SISTEMAS DE PERFILES DE ALUMINIO -----	PA04 -----	<input type="checkbox"/>
PROTECCIONES DE MAQUINARIA -----	SL08 -----	<input type="checkbox"/>
TRANSPORTADORES DE BANDA Y DE RODILLOS -----	PA04 -----	<input type="checkbox"/>
RODILLOS MOTORIZADOS Y DE MANUTENCIÓN -----	I08 -----	<input type="checkbox"/>

GATOS MECANICOS -----	SG12 -----	<input type="checkbox"/>
ACTUADORES LINEALES Serie ATL/BSA -----	SAS09 -----	<input type="checkbox"/>
ACTUADORES LINEALES Serie UAL/UBA -----	SAC09 -----	<input type="checkbox"/>
ACTUADORES LINEALES Serie COMPACTOS -----	AL09 -----	<input type="checkbox"/>
MESAS DE GIRO Y ANILLOS INTERMITENTES -----	TAR11-----	<input type="checkbox"/>
INTERMITORES Y OSCILADORES -----	AOP12 -----	<input type="checkbox"/>
UNIDADES LINEALES Familia PLUS -----	EE11 -----	<input type="checkbox"/>
UNIDADES LINEALES Familia LIGHT -----	LE11 -----	<input type="checkbox"/>
TRANSPORTADOR MECÁNICO DE PRECISIÓN PASO A PASO -----	TEC 08 -----	<input type="checkbox"/>
HUSILLOS DE BOLAS -----	HB 12 -----	<input type="checkbox"/>

ACOPLAMIENTOS Y JUNTAS UNIVERSALES -----	AC03 -----	<input type="checkbox"/>
UNIDADES CÓNICAS DE FIJACIÓN -----	TL04 -----	<input type="checkbox"/>
ENGRANES, CREMALLERAS Y CADENAS -----	EC96 -----	<input type="checkbox"/>
POLEAS Y CORREAS -----	PC96 -----	<input type="checkbox"/>
LIMITADORES DE PAR Y POLEAS VARIADORAS -----	DM98 -----	<input type="checkbox"/>
ACOPLAMIENTOS DE LAMINAS -----	SF09 -----	<input type="checkbox"/>
CADENAS TRANSPORTADORAS DE PASO LARGO Y DE MALLAS -----	ET09 -----	<input type="checkbox"/>
ACOPLAMIENTOS SERIE KTR -----	AK13 -----	<input type="checkbox"/>